

Energizer®



HIGH PRESSURE WASHER

EZN1800/EZN1800-UK

EZN2000/EZN2000-UK

EZN2200/EZN2200-UK

USER GUIDE

CAUTION Read the instructions before using the machine

Energizer®

©2020 Energizer. Energizer and certain graphic designs are trademarks of Energizer Brands, LLC and related subsidiaries and are used under license by Builder SAS.

Let's get started.

You're excited to power up, so we'll keep this brief!

CONTENTS

1. SAFETY WARNINGS	5
2. INTENDED USE	11
3. SYMBOLS	11
4. ASSEMBLY INSTRUCTIONS	13
5. OPERATING INSTRUCTIONS	19
6. INFORMATION FOR USAGE	20
7. CLEAN-UP AND STORAGE	24
8. CLEANING TIPS	25
9. TECHNICAL DATA	26
10. TROUBLESHOOTING TIPS	27
11. WARRANTY	28
12. PRODUCT FAILURE	29
13. WARRANTY EXCLUSIONS	30
14. DECLARATION OF CONFORMITY	31

1. SAFETY WARNINGS

- Use this unit as described in this manual. Any mishandling and any use contrary to instructions shall in no case be the responsibility of the manufacturer.
- Failure to observe the safety and operating instructions may result in a risk of electric shock, fire and/or personal injury.
- If you are giving this unit to another person, please also provide this manual.
- Do not use attachments other than those recommended by the manufacturer; they can damage the unit and/or cause injury.
- Machines should not be used by children. Children should be supervised to ensure that they do not play with the appliance.
- This machine can be used by people with reduced physical, sensory or mental capabilities or lack of experience and knowledge if they have been given supervision or instruction concerning use of the machine in a safe way and understand the hazards involved.
- Children must not play with the appliance.
- If the supply cord is damaged, it must be replaced by the manufacturer, its service agent or similarly qualified persons in order to avoid a hazard.
- Before any connection, check:
 - The appliance, power cable and accessories are not damaged. In this case, do not use the appliance and take it to your dealer for inspection and repair.
 - The voltage indicated on the rating plate of the appliance corresponds to that of your electrical installation.
 - Do not disassemble the device yourself. Any disassembly, repair or inspection should be carried out exclusively by a qualified person.

- Do not touch the plug with wet hands. Do not allow the plug to fall into the water.
- Do not walk on the power cord, do not exert excessive pressure, or pull on the cord to avoid damage.

⚠ WARNING!

- This machine has been designed for use with a cleaning agent supplied or recommended by the manufacturer. Use of other cleaning or chemical agents may affect the safety of the machine.

⚠ WARNING!

- High pressure jets can be dangerous if subject to misuse. The jet must not be directed at persons, live electrical equipment or the machine itself.

⚠ WARNING!

- Do not use the machine within range of persons unless they wear protective clothing.

⚠ WARNING!

- Do not direct the jet against yourself or others in order to clean clothes or footwear.

⚠ WARNING!

- Risk of explosion! Do not spray flammable liquids.

⚠ WARNING!

- High pressure cleaners shall not be used by children or untrained personnel.

⚠ WARNING!

- The machine should be disconnected from its power source during cleaning or maintenance and when replacing parts or converting the machine to another function.

⚠ WARNING!

- High pressure hoses, fittings and couplings are important for the safety of the machine. Use only hoses, fittings and couplings recommended by the manufacturer.

⚠ WARNING!

- To ensure the safety of the machine, use only the original manufacturer's parts or parts approved by the manufacturer.

⚠ WARNING!

- Water that has flowed through backflow preventers is considered to be not drinkable.

⚠ WARNING!

- The machine must be disconnected from the power supply during cleaning or maintenance and when replacing parts or converting the machine to other functions by removing the power source plug.

⚠ WARNING!

- Do not use the machine if a supply cord or important parts of the machine are damaged, e.g. safety devices, high pressure hoses, trigger gun.

⚠ WARNING!

- If an extension cord is used, the plug and cable must be watertight.

⚠ WARNING!

- Inadequate extension cords can be dangerous. If an extension cord is used, it should be suitable for outdoor use, and the connection has to be kept dry and off the ground. It is recommended that this is accomplished by means of a cord reel which keeps the socket at least 60mm above the ground.

⚠ WARNING!

- Make sure there are no exhaust emissions near the air intakes.

- Children, animals and persons not participating in the use of the machine must remain at a minimum distance of 10 metres from the sprayer.
- The high pressure hose must remain connected to the compressor as long as the system is under pressure.
- Do not use corrosive or flammable liquids in the machine.
- The appliance must be connected to a water supply using a new set of hoses; the old pipe set must not be reused.
- Make sure that there are no exhaust emissions near the air inlets.
- When using the machine, wear protective equipment including safety goggles, safety shoes, safety gloves, safety helmet with visor and double-insulated hearing protection.
- In order to move the unit easily, bend the lance.
- Make sure the unit is turned off and unplugged before transporting the unit.
- The connection to the power supply must be made by a qualified electrician in accordance with IEC60364-1. It is recommended that the power supply of this machine includes a residual current device that interrupts power if the earth leakage exceeds 30mA for 30ms with an homologated earth circuit.
- Before assembling, dismantling, repairing, transporting, servicing and storing, please check if the appliance is disconnected from the power supply.
- Handle the unit with care, do not drop it.
- Do not use the machine in extreme weather conditions, when it is very cold. Do not use the machine with ice water.
- Use the tool in a stable and level location.
- The inlet hose can be connected to the water mains with a maximum pressure of 10 bars.

⚠ WARNING!

- In order to avoid any danger due to the accidental reset of the thermal circuit breaker, this device must not be powered via an external switch, such as a timer, or be connected to a circuit which is regularly connected switched on and off by the electricity supplier.
- The appliance must not be connected to drinkable water supply.

⚠ CAUTION!

- In order to avoid danger due to untimely resetting of the thermal cut-out, this device must not be powered by an external switch, such as a timer, or connected to a circuit that is regularly switched on energized and de-energized by the electricity supplier.
- When transporting the machine, take note of its weight. Do not overestimate your efforts and get help if necessary.
- If the machine must be transported from one point to another, please disconnect it. Always use the handle to push the machine.
- Use the handle to lift the machine.
- Improper transport of the machine may result in accidents and injuries.
- Do not use the tool where dangerous situations or accidents may occur. Do not use indoors, or in places where there are exhaust gases, etc.
- In case of an accident or malfunction, stop using the tool, switch off and unplug. Check the conditions of the tool and bring it to a service agent for inspection and reparation if necessary.
- When opening the trigger gun, pay attention to the kickback force. The power of the gun can cause a kickback and can produce a loss of control of the gun and create accidents and injuries. Hold the gun firmly, and with both hands if possible.

⚠ WARNING!

- Always switch off the mains disconnecting switch when leaving the machine unattended.
- To avoid dangerous situations in the event of an accident (for example, contact with or spill of detergents) or equipment failure (such as a puncture or a component failure), please stop using the machine immediately. Check the problem. Have the machine inspected by a qualified technician. In the event of an overflow, move the machine away and clean the overflow.

⚠ WARNING!

- Always turn off the main switch when leaving the machine unattended.
- The tool must always remain upright during use, transport, testing, assembly and disassembly.
- Do not use the tool in dangerous situations or when an accident has occurred.
- Do not use indoors, in places where gases can be emitted, etc.

RESIDUAL RISKS

- Even if you are operating this product in accordance with all the safety requirements, potential risks of injury and damage remain. The following dangers can arise in connection with the structure and design of this product:
 - Health defects resulting from vibration emission if the product is being used over long periods of time or not adequately managed and properly maintained.
 - Danger of injury and property damage caused by flying objects.
 - Injuries and damage to property due to broken accessories or the sudden impact of hidden objects during use.

2. INTENDED USE

Your high pressure washer can perform a myriad of tasks around the house and in the garden. It effectively cleans a wide variety of surfaces.

Your pressure cleaner is designed to operate from a cold water supply.

It operates efficiently with water temperature between 5°C and 40°C (between 41°F and 104°F).

Your high pressure washer has been designed for outdoor use only on materials such as stone, wood and plastics. Please check, before use, whether materials can be cleaned with your sprayer; the manufacturer cannot be held responsible for any damage resulting from improper use.

The main applications of this product are household cleaning tasks such as:







- Cars, motorcycles, bicycles
- Patios, fences, garden walls, pathways, garages and facades of houses
- To remove algae and mosses from roofs, brick walls and gutters
- For cleaning of gardening tools and machinery, furniture and grills
- For hygiene and maintenance of kennels, stables, etc. and their surroundings



It is especially useful for cleaning muddy sidings.

The sprayer alone is capable of performing most of the garden cleaning tasks or on buildings. The detergent is useful for cleaning vehicles and other painted surfaces.

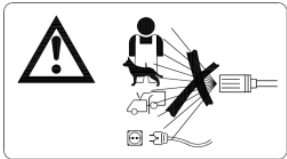
3. SYMBOLS

The labels on your tools and manual may show symbols. These represent important information about the product or instruction on its use.

	Indicates a potential personal injury hazard.
	In accordance with European directives applicable to this product.
	Double-insulated construction.
	To reduce the risk of injury, user must read and understand owner's manual before using this product.
	Always wear safety goggles or safety glasses with side shields and, as necessary, a full face shield when operating this product.
	Warning! Never point the gun at humans, animals, the machine body, power supply or any electric appliances.
	Machine not intended to be connected to the potable water mains.

	<p>Waste electrical products should not be disposed of with household waste, please recycle where facilities exist. Check with your local authority or retailer for recycling advice.</p>
	<p>Recycle unwanted materials instead of disposing of them as waste. All tools, hoses and packaging should be sorted, taken to the local recycling centre and disposed of in an environmentally safe way.</p>

3.1 SERVICING OF A DOUBLE-INSULATED APPLIANCE

In a double-insulated product, two systems of insulation are provided instead of grounding. No means of grounding is provided on a double-insulated product, nor should a means for grounding be added to the product. Servicing a double-insulated product requires extreme care and knowledge of the system, and should be done only by qualified service personnel. Replacement parts for a double-insulated product must be identical to the parts they replace. A double-insulated product is marked with the words “DOUBLE INSULATION” or “DOUBLE INSULATED”. This symbol  may also be marked on the product.

4. ASSEMBLY INSTRUCTIONS

4.1 UNPACKING THE CARTON

After opening the carton, please remove all parts and check them against the following list of components that are included:

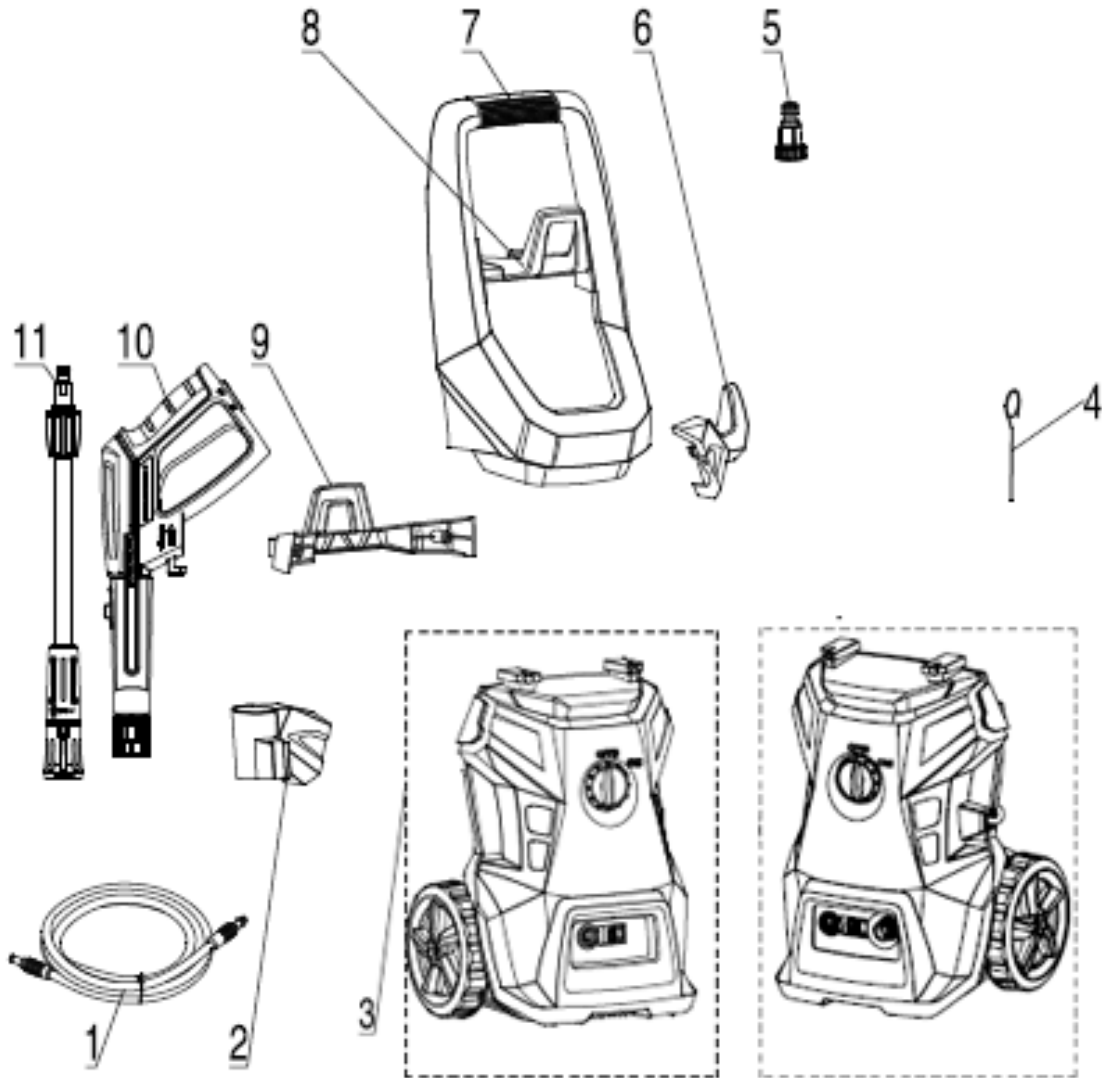

Models:

EZN1800

EZN1800-UK

Models:

EZN2000

EZN2000-UK

1.	High pressure hose	5.	Water inlet connector	9.	Accessories holder
2.	Gun holder	6.	Power cable hook	10.	Gun
3.	Power washer unit	7.	Handle	11.	Adjustable nozzle
4.	Cleaning pin	8.	High pressure hose hook		

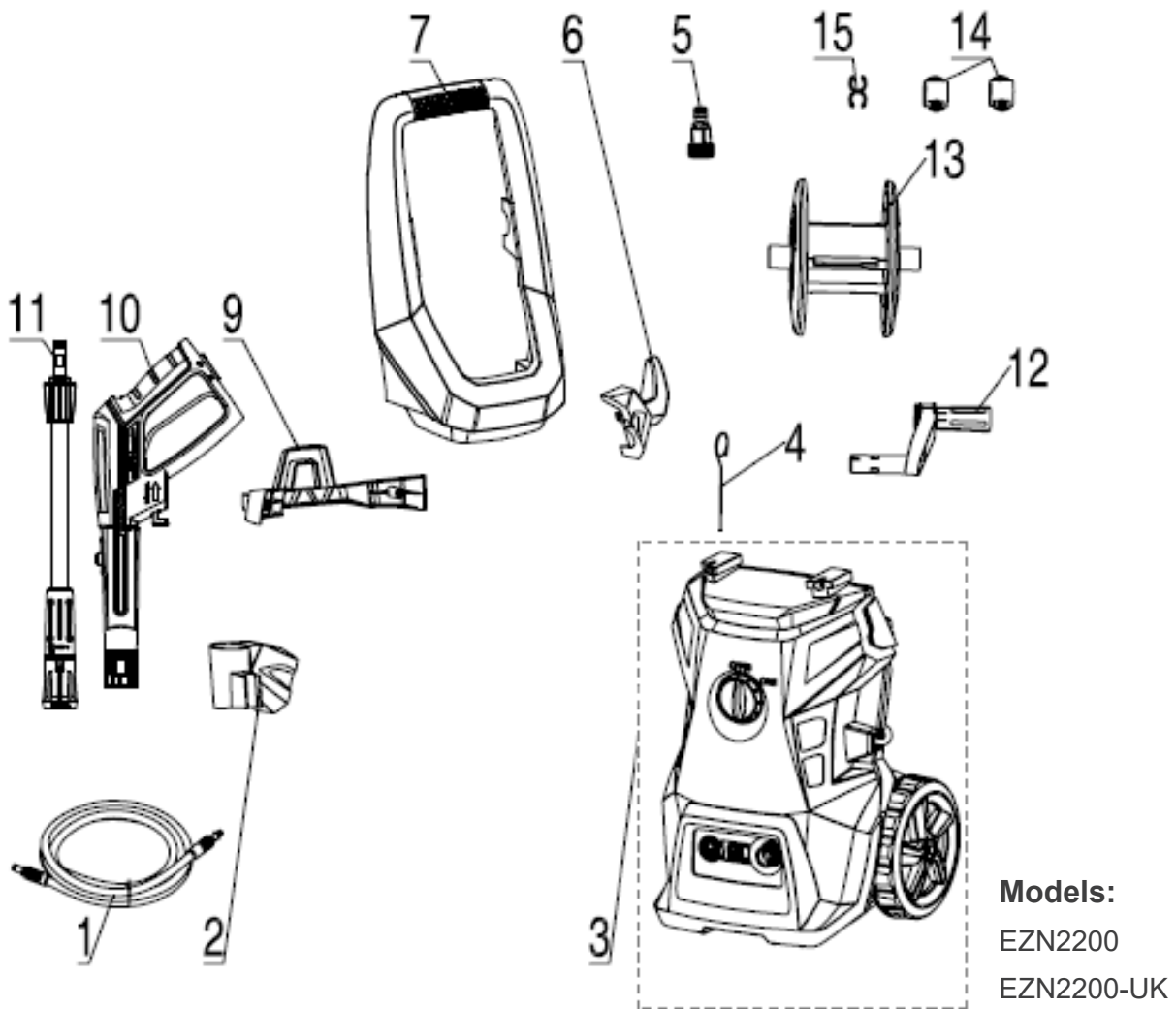

1.	High pressure hose	6.	Power cable hook	12.	Hose reel handle
2.	Gun holder	7.	Handle	13.	Hose reel
3.	Power washer unit	9.	Accessories holder	14.	Hose support
4.	Cleaning pin	10.	Gun	15.	Pressure hose clip
5.	Water inlet connector	11.	Adjustable nozzle		

Due to transportation and packaging, some of the accessories may be supplied disassembled. Please follow the assembly instructions.

Always transport the machine by the handle.

STEP 1

Screw the accessories holder tight to the main body.(Fig.1).

Screw the high pressure hose hook tight to the handle, then screw the handle tight to the main body (for model EZN1800/EZN1800-UK/EZN2000/EZN2000-UK). (Fig.2A & 2B)

Install the two supports of the hose on the hose reel, and then install the handle to the hose reel. Then install the hose reel on the handle of the machine. Finally install the handle on the machine body and screw it in place (for EZN2200 / EZN2200-UK models). (Fig.2-B)

Install gun holder and power cord hook. (Fig.3)

Fig.1

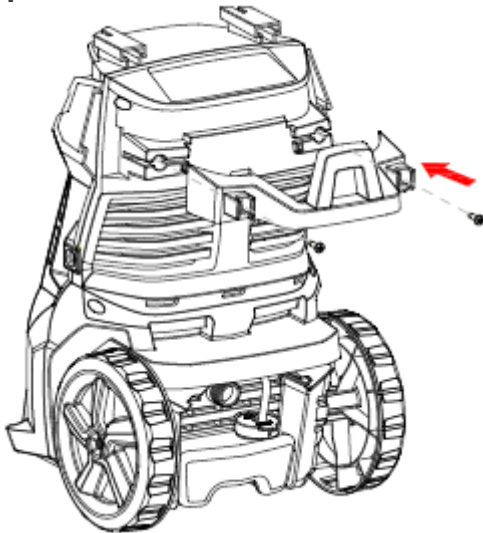

Fig.3

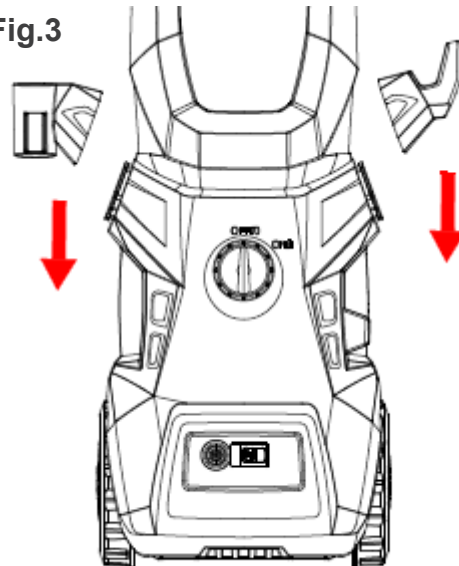
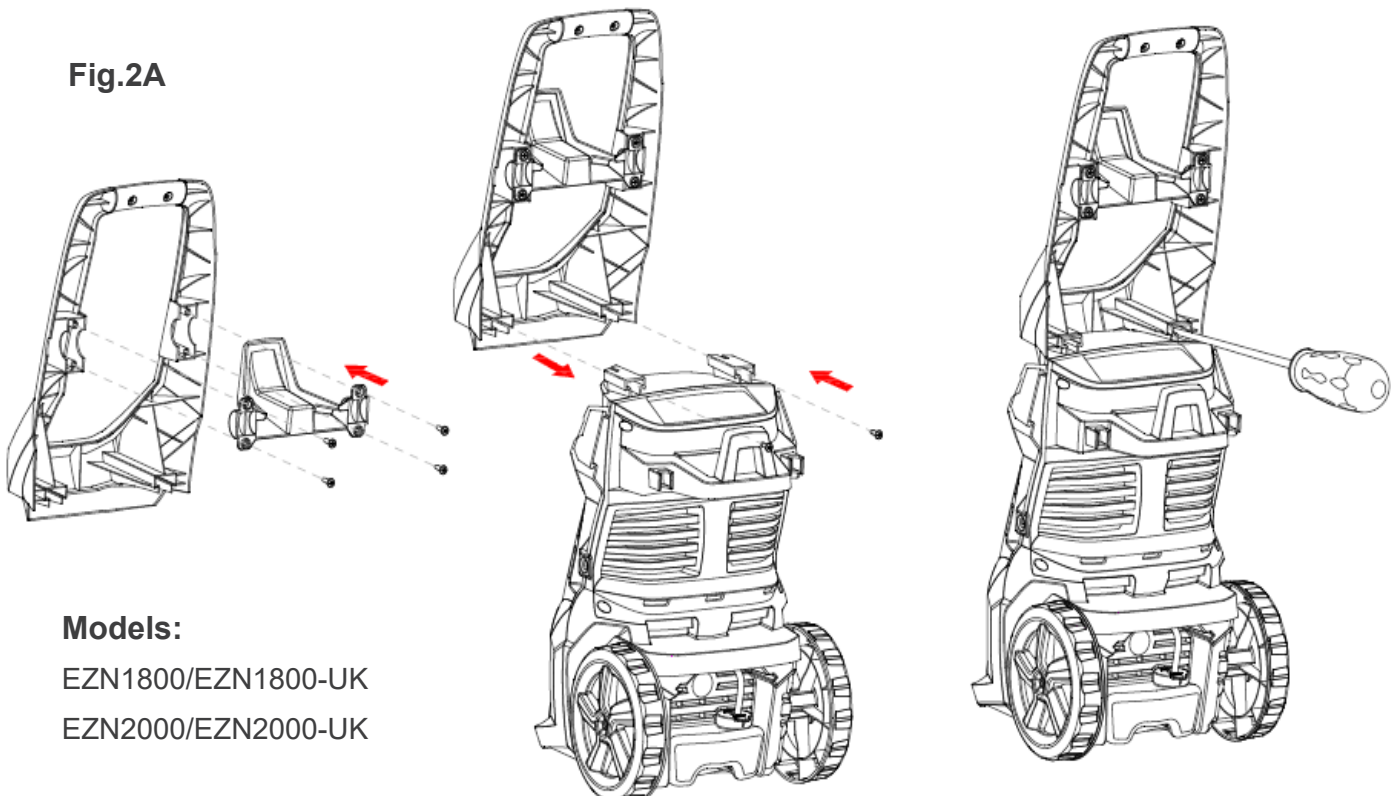

Fig.2A



Models:

EZN1800/EZN1800-UK
EZN2000/EZN2000-UK

Fig.2B

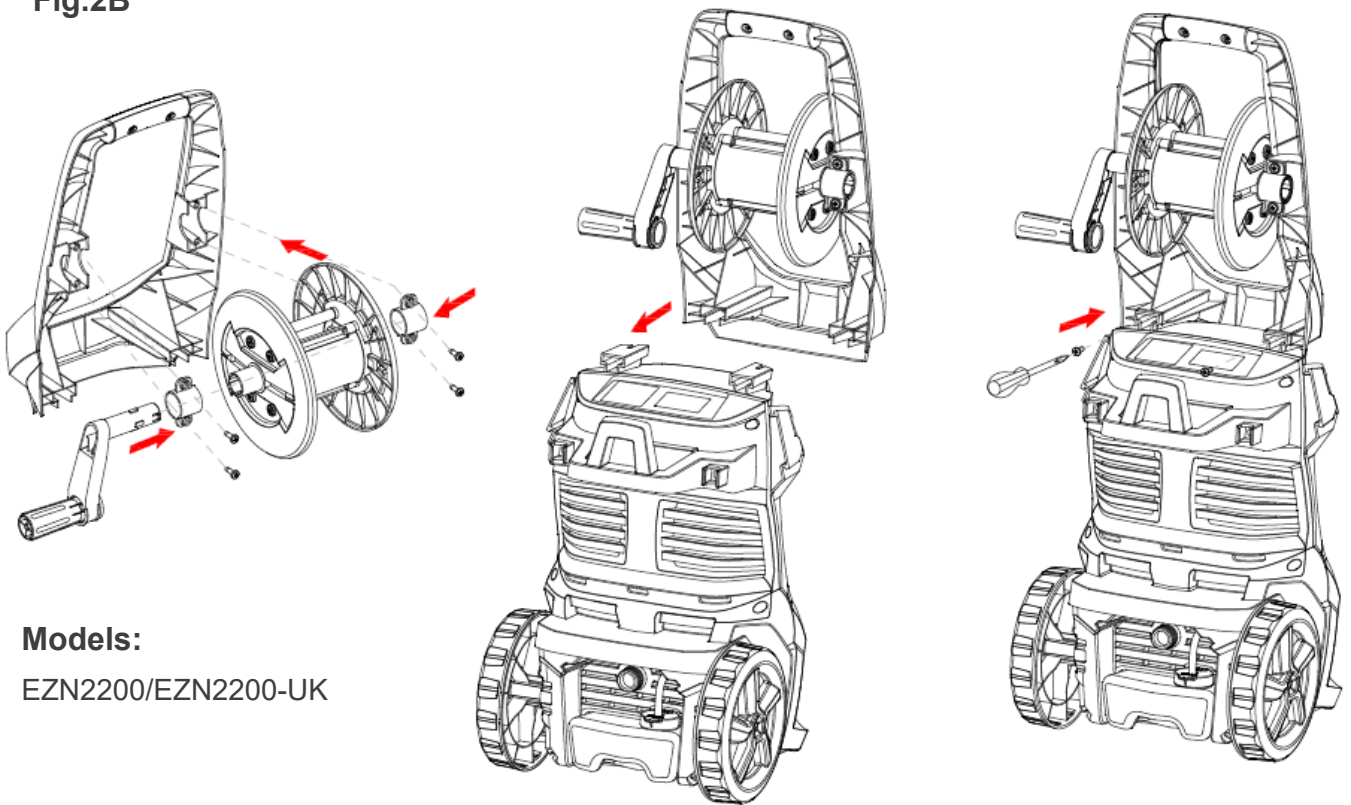

Models:

EZN2200/EZN2200-UK

STEP 2

Attach the high pressure hose to the pressure cleaner water outlet. Insert and quick-connect it tight to avoid leakage. When the pieces are joined properly, you cannot separate the two components by pulling straight out from the water outlet. Push the "Button" according to the direction of arrow, then you can pull out the high pressure hose. (Fig.4)

Fig.4

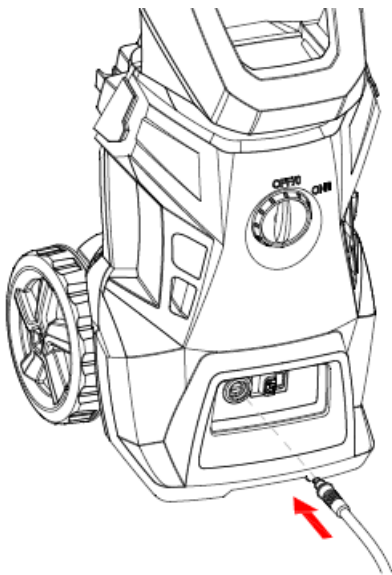
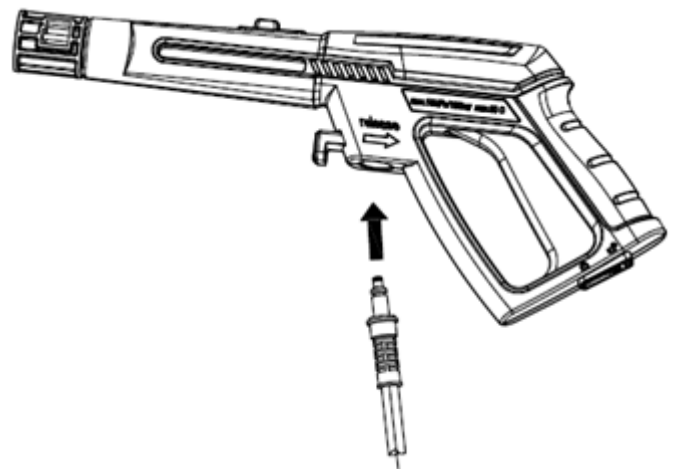

Fig.5



STEP 3

Attach the high pressure hose to the gun. Insert and quick-connect it tight to avoid leakage. When the pieces are joined properly, you cannot separate the two components by pulling straight out from the gun. Push the hose lock button, then you can pull out high pressure hose. (Fig.5)

STEP 4

Attach the hose connector to pressure washer. Before attaching the connector to the male fitting, remove the plastic cap, which is inserted onto the male fitting on the pressure washer before shipping. This plastic cap can be discarded once removed. After both components have been installed, attach the garden hose with connector screw on the pressure washer. Connect the garden hose to the water supply.

⚠ WARNING!

Ensure water inlet hose is not damaged or leaking, the inner diameter of the hose must not be less than 1/2 inch and the length of the hose must not be longer than 8 metres.

Models:

EZN1800

EZN1800-UK



Models:

EZN2000/EZN2000-UK

EZN2200/EZN2200-UK

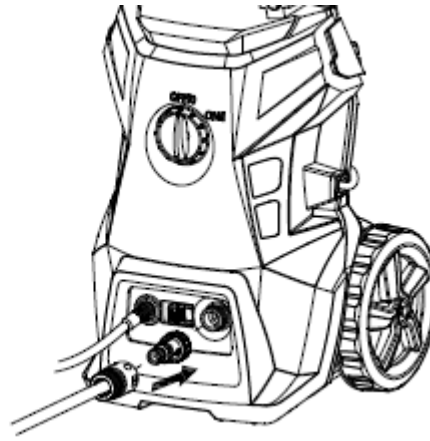

STEP 5 - INSTALLATION OF THE ACCESSORIES

Install the correct accessories following below operations

Adjustable spray nozzle

Insert the adjustable spray nozzle into the gun. Push and turn the adjustable nozzle anticlockwise onto the gun and turn it anticlockwise to lock it in place.

To remove the adjustable spray nozzle, turn it clockwise and remove it from the gun.

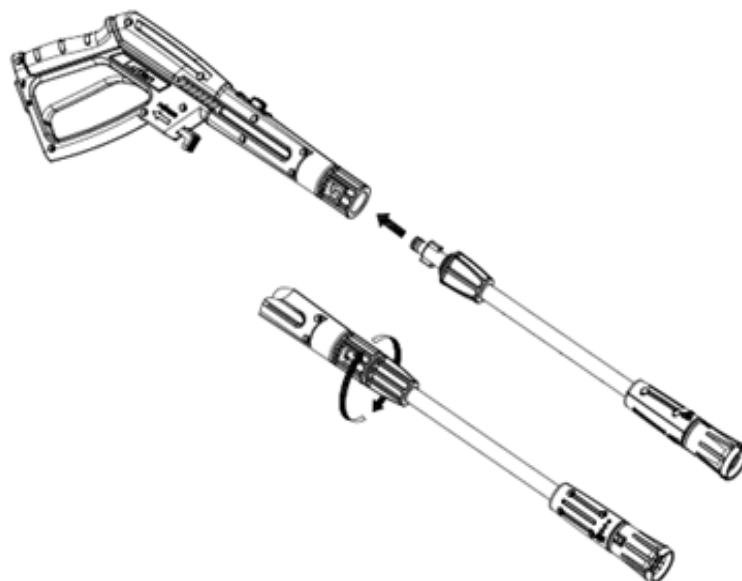



Surface cleaner

- Screw the extension tube to the surface cleaner.
- Insert the additional tube on the gun and then turn it anticlockwise to lock it in place.
- To remove the accessory, push the extension tube and turn it clockwise to remove it.
- Unscrew the additional tube from the surface cleaner to remove it.

Fix brush

Correctly align the brush with the gun. Push the brush inside the gun. Turn it anticlockwise to lock it in place.

To remove it, push the accessory back, turn it clockwise, and then remove it.

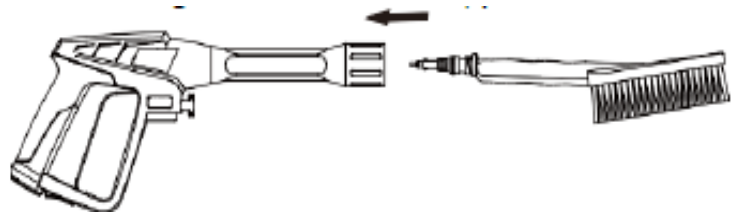

Rotating brush (Only for EZN2200 and EZN2200-UK)

Correctly align the rotating brush with the gun. Push the brush inside the gun. Turn it anticlockwise to lock it in place. To remove it, push the accessory back, turn it clockwise, and then remove it.

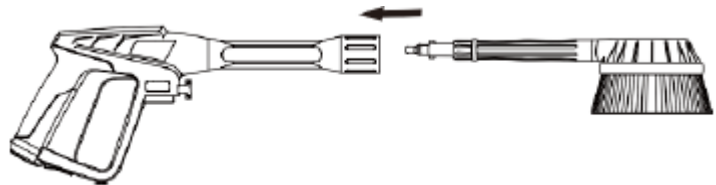

Extension gun

Correctly align the extension gun with the gun. Push the extension gun inside the gun. Turn it anticlockwise to lock it in place. To remove it, push the accessory back, turn it clockwise, and then remove it.



5. OPERATING INSTRUCTIONS

⚠ WARNING!

This unit is intended to be used with cold water only! Do not use hot water in this pressure cleaner!
High pressure hose must not loop.

⚠ WARNING!

During operation the appliance must be positioned on a firm and stable surface.

5.1 STARTING UP

⚠ WARNING!

ALWAYS turn off the unit's motor **BEFORE** turning off the unit's water supply.
Serious damage could occur to the motor if the unit is run without water.

- a) Turn on the water supply tap fully.
- b) Unlock trigger (by pressing the safety button first and then actuate the trigger) for a few seconds; let the water flow out from the nozzle.
- c) Check if water leaks from joints. If water leaks, please reconnect the water hose, the spray gun or the lance to make sure each accessory is connected perfectly.
- d) Connect to power supply.
- e) Set the power switch at the position «I».(Fig.6)
- f) Actuate the trigger and start the washer.

Fig.6



⚠ WARNING!

Check that the supply voltage and frequency correspond to those specified on the appliance data plate. The appliance should only be connected to a mains power supply via a security breaker (Max.30mA) to cut off the electricity supply in the instance of a short circuit.

5.2 STOPPING THE WASHER

⚠ WARNING!

ALWAYS turn off the unit's motor **BEFORE** turning off the unit's water supply.
Serious damage could occur to the motor if the unit is run without water.

- a) Release the trigger, the motor will stop operation.
- b) Set the switch at the position «O».(Fig.6)
- c) Disconnect the plug from the socket.

⚠ WARNING!

Failure to follow the above instructions may cause damage to the machine.

5.3 CHANGING ACCESSORIES

- a) Release the trigger.
- b) Turn off the power switch (the position «O»).(Fig.6)
- c) Disassemble the accessory and assemble the other one (see “4. ASSEMBLY INSTRUCTIONS - Step 5”).

! WARNING!

Never disconnect the high-pressure discharge hose from the machine while the system is still pressurized . To depressurize the unit, turn off the motor, turn off the water supply and squeeze the trigger 2-3 times.

6. INFORMATION FOR USAGE

6.1 SAFETY VALVE AND/OR PRESSURE LIMITING VALVE

! WARNING!

Do not tamper with or adjust the safety valve setting.

The safety valve is also a pressure limiting valve. When the gun trigger is released, the valve opens, the pressure switch activates and the machine automatically shuts down.

If the gun nozzle is blocked, it will cause the machine pressure to rise, the safety valve to open, it will activate the pressure switch and the machine will automatically shut down. You can refer to the following point 7 and use a needle to clean the nozzle.

6.2. AUTOMATIC ON/OFF

The pressure cleaner is equipped with an automatic on/off switch. The pressure cleaner will only run when the power switch is in the ON position and the trigger on the gun is squeezed. When you release the trigger to stop spraying water through the gun, the motor on the pressure cleaner will automatically shut off. Simply squeeze the trigger again to resume using the cleaner. To stop using the pressure cleaner, release the trigger and switch the unit to the OFF position. The unit should be turned completely OFF while not in use or while unattended.

6.3. BLEEDING THE GUN

It is very important to bleed the gun before using the pressure cleaner. Refer to the “Assembly Instructions” to assemble the pressure cleaner. To bleed the gun, simply connect the garden hose to the pressure cleaner and squeeze the trigger BEFORE turning the electrical supply on. This allows any air trapped inside the pressure cleaner and gun to be removed before using the unit. Continue holding trigger for approximately one minute to allow any excess air out of the unit. Water will flow through the gun at low pressure during this procedure. For more bleeding tips, see the section titled “Operating Instructions.”

6.4 GUN SAFETY LOCK

This pressure cleaner is equipped with a gun trigger safety lock. When not using the pressure cleaner, use the safety lock to keep from accidentally engaging the high pressure spray (Fig.7).

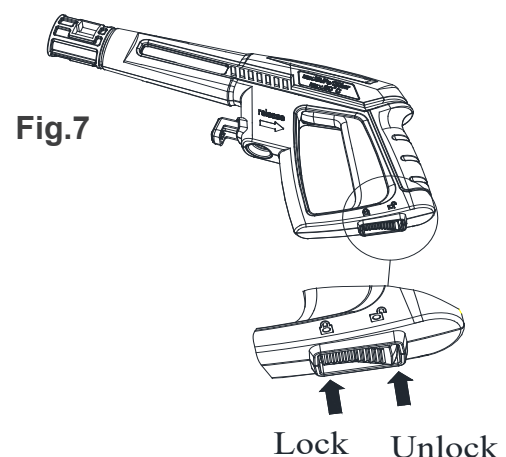

6.5 ADJUSTABLE SPRAY NOZZLE

The adjustable nozzle will allow you to use any variety of spray patterns from a full fan spray (Fig.8 - Diagram 1) to a direct stream spray (Fig.8 - Diagram 2). When using the pressure washer to clean wood decks, siding, vehicles, etc., always start using the fan spray and begin spraying from a minimum 36" away to avoid damaging the surface of the material you are cleaning. Always begin by spraying in a testing area free and clear of people and objects.

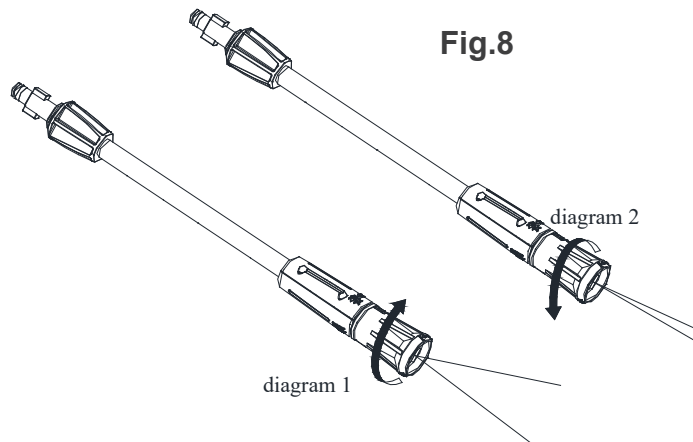

Fig.8

! WARNING!

- High pressure jets can be dangerous if subject to misuse. The jet must not be directed at persons, live electrical equipment or the appliance itself.
- Do not direct the jet against yourself or others in order to clean clothes or footwear.

6.6 SURFACE CLEANER

The surface cleaner allows efficient cleaning of terraces, paths and similar large surfaces. This function provides the user with optimum splash protection. The high pressure nozzles in the cleaning housing are rotated by water pressure. The housing and tight brushes close to the edge prevent splashing.

Place the surface cleaner on the surface to be cleaned and turn on the high pressure cleaner, as described above. Without too much pressure, guide the surface cleaner onto the surface to be cleaned.

ATTENTION: Never operate the spray gun trigger until the surface cleaner is placed on the surface to be cleaned.

You can remove algae, moss and other dirt of the same type from terraces, paths and similar surfaces without splashing.

6.7 ROTATE THE GUN

Rotating the gun to adjust the cleaning angle will help make users comfortable and contribute to efficient cleaning.

Slide button to «unlock» to use the rotating function; slide to «lock» to lock the position of the gun.

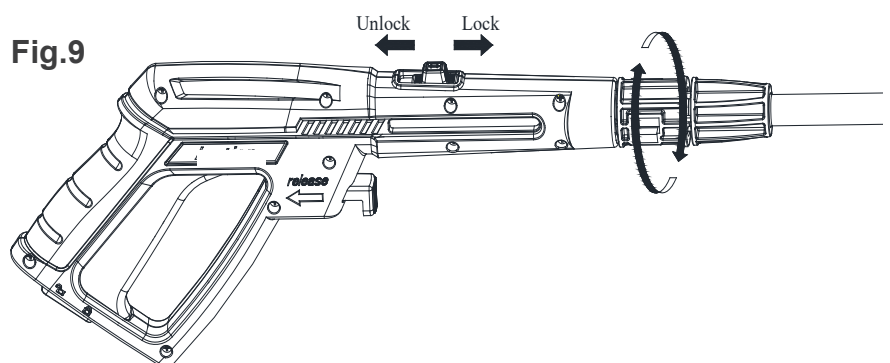
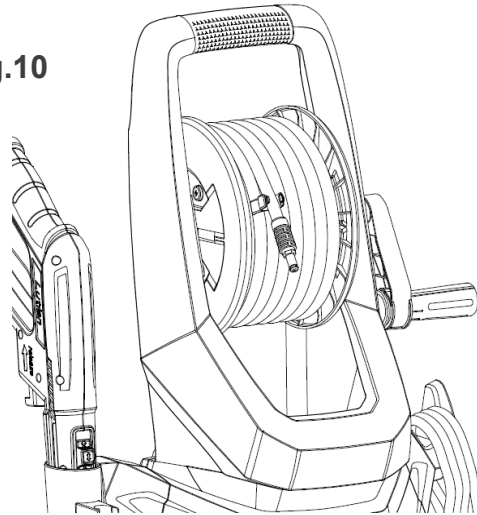

Fig.9

6.8 HOSE REEL

For EZN2200 and EZN2200-UK models, there will be a hose reel fixed on the handle, you can wrap the hose around this hose reel and fix it tightly with a specified clip provided by the manufacturer when not in use.

Fig.10



6.9 WATER INLET SCREEN

The water inlet filter must be inspected regularly, so as to avoid blockage and restriction in the water supply to the pump.

Fig.11

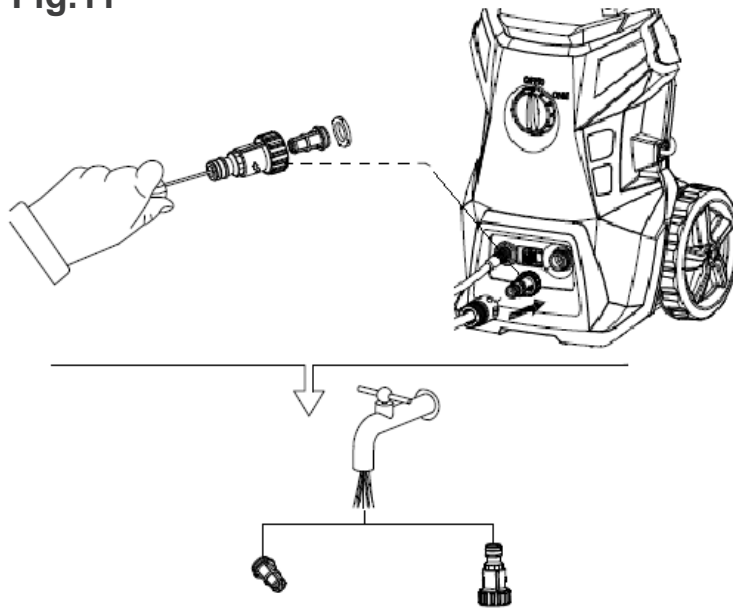

6.10 UNBLOCK LANCE

When the nozzle is clogged, it will cause the pump to build pressure and may cause the unit to surge, you can clean the nozzle inserting needle into the tip to rid of the deposits.

For the adjustable nozzle, you can lubricate the nozzle collar (high pressure to low pressure) by using non-water soluble grease regularly.

Fig.12

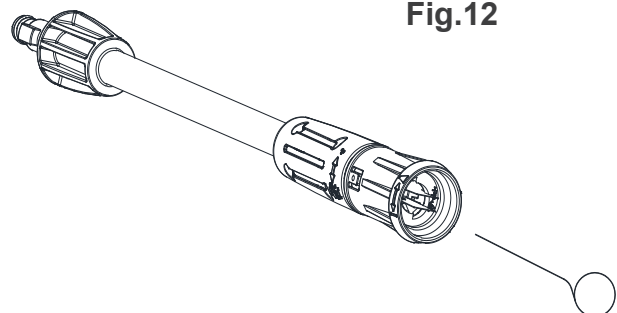

6.11 USING DETERGENTS

The pressure cleaner will dispense detergent at low pressure. Use the adjustable spray nozzle to rinse clean.

Biodegradable detergents are specifically formulated to protect the environment and your pressure cleaner.

These detergents will not clog the filter and will protect the internal parts of the pressure cleaner for a longer life.

The built-in detergent dispenser will allow you to apply many forms of liquid detergent onto the work surface. Detergent application happens at low-pressure only. Insert the adjustable nozzle onto the gun, and turn it to end of “☼”, so that the pressure washer is in low-pressure mode (see Fig.13A below). Remove the cap on the detergent reservoir and fill with liquid detergent only (see Fig.13B below). Do not put any water into the reservoir. The pressure washer will mix water and detergent automatically. When finished applying the detergent to the work surface, turn it to end of “☼” of the adjustable nozzle and spray off the detergent by using the high-pressure spray (see Fig.13A below). In high-pressure mode, the pressure washer will not dispense detergent.

Fig.13A

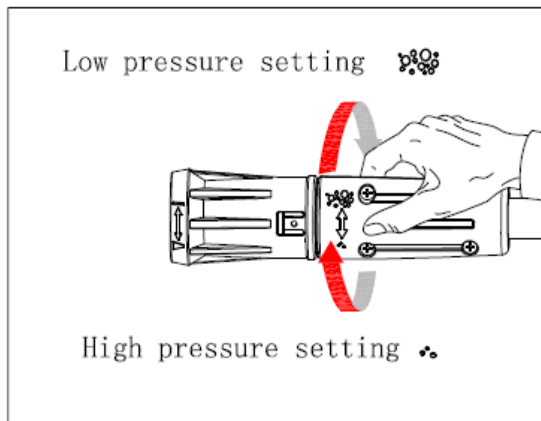
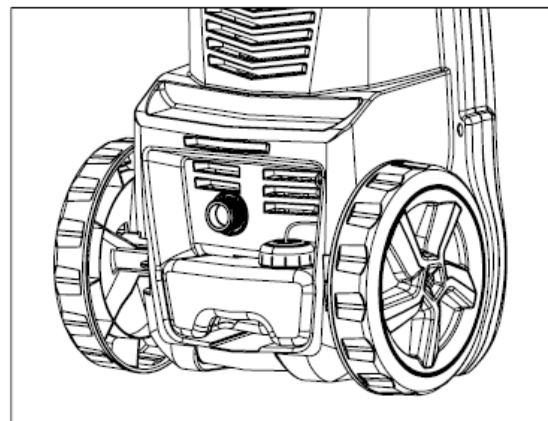

Fig.13B



⚠ WARNING!

Never use products with bleach or chlorine or any other corrosive materials, including liquids containing solvents (i.e. gas, oils etc), tri-sodium phosphate products, ammonia, or acid-based cleaners. These chemicals will harm the unit and cause damage to the surface being cleaned. Always read the label.

7. CLEAN-UP AND STORAGE

7.1 SHUTTING DOWN THE PRESSURE CLEANER

When finished using the pressure cleaner, follow these steps to shut down the unit:

- Turn the pressure cleaner to the OFF position, unplug the power cord from the wall outlet.
- Turn off the water supply.
- Before disconnecting high-pressure hose connection, point the gun in a safe direction and discharge the high-pressure water.
- Disconnect high-pressure hose from the pressure cleaner and gun.
- Disconnect garden hose from the pressure cleaner.
- Remove quick coupler fitting from garden hose and attach to the nipple portion of the fitting installed on the pressure cleaner for storage.
- Remove excess water from the pump by tipping the unit on both sides to drain any remaining water from inlet and outlet fittings.
- Remove water intake filter and flush with water to remove dirt or debris. Return filter once cleaned.
- Drain detergent reservoir and flush with running water.
- Wipe away any remaining water on all parts and fittings.
- Engage the gun safety lock.
- Store the pressure cleaner, parts, and accessories in an area with a temperature above 0°C (32°F).

7.2 WINTERIZING AND LONG-TERM STORAGE

Follow all of the above shut-down procedures, adding the following steps...

- After disconnecting the water supply, and before disconnecting the high-pressure hose, turn the pressure cleaner on for 2-3 seconds, until any remaining water in the pump exits. **Turn unit off immediately.**

WARNING!

Continued use of the pressure cleaner without water supply attached will cause severe damage to the unit!

- Always store the pressure cleaner, parts, and accessories in an area with a temperature above 0°C (32°F).

WARNING!

Failure to comply with these storage instructions will result in damage to the pump assembly.

7.3 MAINTENANCE

- This pressure cleaner is supplied with a closed lubrication system, so no addition of oil is needed.
- Check all hoses and accessories for damage prior to use.
- Check the inlet filter periodically for deposits. Clean this filter regularly for maximum performance.

8. CLEANING TIPS

WARNING!

Always test the spray in an area free and clear of people and objects before you spray at the intended cleaning surface.

8.1 WOOD AND VINYL DECKS

Rinse deck and surrounding area with fresh water. If using detergent, fill the detergent reservoir and apply to the area being cleaned at low pressure. For optimal results, reduce your work area to smaller sections and clean each section one at a time. Allow the detergent to rest on the surface for a few minutes **and then** rinse at high pressure. **Do not let the cleanser dry.** Always clean from left to right and top to bottom for best results. Rinse at high pressure **using the fan spray** keeping the tip of the spray nozzle at least 6-9 inches from the cleaning surface. Maintain a further distance from the cleaning area when using a direct spray. **Caution: For softer woods, increase the distance from the cleaning area.**

8.2 CEMENT PATIOS, STONE, AND BRICK

Rinse cleaning and surrounding area with fresh water. If using detergent, fill the detergent reservoir and apply to the area being cleaned at low pressure. Rinse at high pressure **using the fan spray** in a sweeping motion keeping the tip of the spray nozzle at least 3-6 inches from the cleaning surface. Maintain a further distance from the cleaning area when using a direct spray.

8.3 CARS, BOATS, AND MOTORCYCLES

Rinse cleaning and surrounding area with fresh water. If using detergent, fill the detergent reservoir and apply to the area being cleaned at low pressure. To achieve the best results, clean one side at a time. Allow the detergent to rest on the surface for a few minutes, but do not let the detergent dry. Rinse at high pressure **using the fan spray** in a sweeping motion keeping the tip of the spray nozzle at least 8 inches from the cleaning surface. Maintain a further distance from the cleaning area when using a direct spray. Wipe surface dry for a polished finish.

8.4 BARBECUE GRILLS, POWER EQUIPMENT, AND GARDEN TOOLS

Rinse cleaning and surrounding area with fresh water. If using detergent, fill the detergent reservoir and apply to the area being cleaned at low pressure. Allow the detergent to rest on the surface for a few minutes, but do not let the detergent dry. Rinse at high pressure **using the fan spray** keeping the tip of the spray nozzle at least 1-3 inches from the cleaning surface. Maintain a further distance from the cleaning area when using a direct spray.

9. TECHNICAL DATA

Model	EZN1800/ EZN1800-UK	EZN2000/ EZN2000-UK	EZN2200/ EZN2200-UK
Rated voltage	AC 220-240V~ 50/60Hz		
Rated power	1800 W	2000 W	2200 W
Rated pressure	10 MPa	11 MPa	12 MPa
Allowable pressure	14 MPa	16 Mpa	17 MPa
Rated flow	6.5 L/min		
Max. flow	7.5 L/min		
Max. water inlet pressure	1.2 MPa		
Max. water inlet temperature	50°C		
Class protection	Class II		
Degree of protection	IPX5		
Sound pressure level (K=3dB(A)):LpA	74.3 dB(A)		
Sound power level(K=3dB(A)):LwA	87 dB(A)		
Guarantee sound power level	89 dB(A)		
Vibration value(K=1.5m/s ²)	≤2.5 m/s ²		
Weight	7.8 kg	8.28 kg	8.96 kg



Guarantee noise level

GUARANTEE

Refer to the enclosed guarantee conditions for the terms and conditions of guarantee.

ENVIRONMENT

Should your machine need replacement after extended use, do not put it in the domestic waste but dispose of it in an environmentally safe way.

10. TROUBLESHOOTING TIPS

WHEN THE SWITCH IS IN THE "I" POSITION THE MACHINE WILL NOT START

PROBABLE CAUSE	SOLUTION
Electrical socket is faulty	Check plug, socket, fuses
Voltage is inadequate	Check whether the voltage is adequate
Power cord is not plugged in	Plug in power cord

THE PUMP DOES NOT REACH ADEQUATE PRESSURE OR FLUCTUATES

PROBABLE CAUSE	SOLUTION
Water inlet filter is clogged	Remove and clean filter
Pump is drawing air	Tighten connections/bleed system
Suction valves are clogged/worn	Clean or replace valves
Diameter of garden hose too small	Replace with ¾ inch garden hose
Water supply is restricted	Check hose for kinks or leaks
Insufficient water supply	Fully open water source

THE PRESSURE CLEANER HAS OR WILL NOT MAINTAIN PRESSURE

PROBABLE CAUSE	SOLUTION
Excessive air in waterline and pump	Turn unit and water supply off
	Bleed system/Hold trigger down

THE PRESSURE CLEANER MAKES EXCESSIVE NOISE

PROBABLE CAUSE	SOLUTION
Intake is blocked	Check the intake valves
Valves are worn, dirty, or clogged	Check, clean or replace valves
Filter is dirty	Check, clean, or replace filter

THE MOTOR STOPS RUNNING WHILE IN USE

PROBABLE CAUSE	SOLUTION
Net voltage lower than suggested	Check whether the voltage is adequate

11. WARRANTY

Energizer[®]

WARRANTY

The manufacturer guarantees the product against defects in material and workmanship for a period of 2 years from the date of the original purchase. The warranty only applies if the product is for household use. The warranty does not cover breakdowns due to normal wear and tear.

The manufacturer agrees to replace parts identified as defective by the designated distributor. The manufacturer does not accept responsibility for the replacement of the machine, in whole or in part, and/or ensuing damage.

The warranty does not cover breakdowns due to:

- insufficient maintenance.
- abnormal assembly, adjustment or operations of the product.
- parts subject to normal wear and tear.

The warranty does not extend to:

- shipping and packaging costs.
- using the tool for a purpose other than that for which it was designed.
- the use and maintenance of the machine done in a manner not described in the user manual.

Due to our policy of continuous product improvement, we reserve the right to alter or change specifications without notice. Consequently, the product may be different from the information contained therein, but a modification will be undertaken without notice if it is recognized as an improvement of the preceding characteristic.

READ THE MANUAL CAREFULLY BEFORE USING THE MACHINE.

When ordering spare parts, please indicate the part number or code, you can find this in the spare parts list in this manual. Keep the purchase receipt; without it, the warranty is invalid. To help you with your product, we invite you to contact us by phone or via our website:

- **+33 (0)9.70.75.30.30**
- **<https://services.swap-europe.com/contact>**

You must create a "ticket" via the web platform.

- Register or create your account.
- Indicate the reference of the tool.
- Choose the subject of your request.
- Describe your problem.
- Attach these files: invoice or sales receipt, photo of the identification plate (serial number), photo of the part you need (for example: pins on the transformer plug which are broken).



12. PRODUCT FAILURE

WHAT TO DO IF MY MACHINE BREAKS DOWN?

If you bought your product in a store:

- a) Empty the fuel tank.
- b) Make sure that your machine is complete with all accessories supplied, and clean! If this is not the case, the repairer will refuse the machine.

Go to the store with the complete machine and with the receipt or invoice.

If you bought your product on a website:

- a) Empty the fuel tank.
- b) Make sure that your machine is complete with all accessories supplied, and clean! If this is not the case, the repairer will refuse the machine.
- c) Create a SWAP-Europe service ticket on the site: <https://services.swap-europe.com> When making the request on SWAP-Europe, you must attach the invoice and the photo of the nameplate (serial number).
- d) Contact the repair station to make sure it is available before dropping off the machine.

Go to the repair station with the complete machine packed, accompanied by the purchase invoice and the station support sheet downloadable after the service request is completed on the SWAP-Europe site

For machines with engine failure from manufacturers BRIGGS & STRATTON, HONDA and RATO, please refer to the following instructions.

Repairs will be done by approved engine manufacturers of these manufacturers, see their site:

- <http://www.briggsandstratton.com/eu/fr>
- <http://www.honda-engines-eu.com/fr/service-network-page;jsessionid=5EE8456CF39CD572AA2AEEDFD290CDAE>
- <https://www.rato-europe.com/it/service-network>

Please keep your original packaging to allow for after-sales service returns or pack your machine with a similar cardboard box of the same dimensions.

For any question concerning our after-sales service you can make a request on our website <https://services.swap-europe.com>

Our hotline remains available at +33 (9) 70 75 30 30.



13. WARRANTY EXCLUSIONS

THE WARRANTY DOES NOT COVER:

- Start-up and setting up of the product.
- Damage resulting from normal wear and tear of the product.
- Damage resulting from improper use of the product.
- Damage resulting from assembly or start-up not in accordance with the user manual.
- Breakdowns related to carburetion beyond 90 days and fouling of carburetors.
- Periodic and standard maintenance events.
- Actions of modification and dismantling that directly void the warranty.
- Products whose original authentication marking (brand, serial number) has been degraded, altered or withdrawn.
- Replacement of consumables.
- The use of non-original parts.
- Breakage of parts following impacts or projections.
- Accessories breakdowns.
- Defects and their consequences linked to any external cause.
- Loss of components and loss due to insufficient screwing.
- Cutting components and any damage related to the loosening of parts.
- Overload or overheating.
- Poor power supply quality: faulty voltage, voltage error, etc.
- Damages resulting from the deprivation of enjoyment of the product during the time necessary for repairs and more generally the costs related to the immobilization of the product.
- The costs of a second opinion established by a third party following an estimate by a SWAP-Europe repair station
- The use of a product which would show a defect or a breakage which was not the subject of an immediate report and/or repair with the services of SWAP-Europe.
- Deterioration linked to transport and storage*.
- Launchers beyond 90 days.
- Oil, petrol, grease.
- Damages related to the use of non-compliant fuels or lubricants.

* In accordance with transport legislation, damage related to transport must be declared to carriers within 48 hours maximum after observation by registered letter with acknowledgement of receipt.

This document is a supplement to your notice, a non-exhaustive list.

Attention: all orders must be checked in the presence of the delivery person. In case of refusal by the delivery person, it you must simply refuse the delivery and notify your refusal.

Reminder: the reserves do not exclude the notification by registered letter with acknowledgement within 72 hours.

Information:

Thermal devices must be wintered each season (service available on the SWAP-Europe site). Batteries must be charged before being stored.

14. DECLARATION OF CONFORMITY

We hereby declare that the design, construction and the model for the device with the standard and the requirements of safety and health of the EU's consistent policy.

The statement will prove ineffective if the device is being modified without our approval.

Type of instrument:

Pressure Cleaner

- EZN1800/EZN1800-UK
- EZN2000/EZN2000-UK
- EZN2200/EZN2200-UK

Serial number :

20210123222-20210123371

20210123372-20210123521

• EU Directives:

- EU Machinery Directive 2006/42/EC
- EU Directive Electromagnetic Compatibility 2014/30/EC
- ROHS Directive 2011/65/EU and amendment 2015/863/EU

Noise Directive 2000/14/EC+2005/88/EC

Measured sound power level: 87 dB Guaranteed sound power level: 89 dB

Applied harmonized standards:

- EN60335-2-79:2012
- EN 60335-1: 2012+A11:2014+A13:2017
- EN 55014-1:2017
- EN 55014-2:2015
- EN 61000-3-2:2014
- EN 61000-3-3:2013
- EN 62233:2008

Cugnaux, 01/01/2021



Philippe MARIE / CEO

Energizer®